

Design Specification # 500-2011  
Model DS-100 P/N 500-2011  
429 to XYZ Adapter  
NOVEMBER 18, 1994

Skylight Avionics  
38629 6th St. East  
Palmdale, Ca. 93550  
(661)265-0497

TABLE OF CONTENTS

REFERNCE	SECTION	PAGE
(i)	OPERATING INSTRUCTIONS	1
(ii)	EQUIPMENT LIMITATIONS	1
(iii)	INSTALLATION PROCEDURES & LIMITATIONS	2
(iv)	INSTALLATION MECHANICAL DIAGRAMS	3
(v)	INSTALLATION WIRING DIAGRAMS	4
(vi)	SPECIFICATIONS	5
(vii)	EQUIPMENT SYSTEM - MAJOR COMPONENTS	6
(viii)	ENVIRONMENTAL QUALIFICATION FORM	7

**Illustrations**

Illustration	Title	Page
(iv-1)	Mechanical Installation Drawing	3
(v-1)	Electrical Pinout Drawing	4
(vii-1)	Interconnect Block Diagram	6

(i) OPERATING INSTRUCTIONS

The D/S-100 Adapter by it's design has no independent operating instructions or controls. Being a format adapter for digital to synchro only and transparent to the system connected the operating instructions for that system will need to be followed.

(ii) EQUIPMENT LIMITATIONS

The D/S-100 adapter was designed using the pertinent RTCA/DO160B sections. In being an integral part of a Direction Instrument. SAE AS 8013 and AS 8021 Minimum Performance Standard for Direction Instrument Magnetic and Non-Magnetic (Gyroscopically Stabilized) was used as a guide line. However the D/S-100 is a format adapter only used to adapt ARINC 429 to Synchro only.

The D/S-100 adapter, as a component of the on board Direction Instrument System, the update speed and accuracy is directly limited to the output of the ARINC 429 Transmitter which is driving the D/S-100. In effect, it is a component of that system and therefore subject to all inherent limitations of that system.

The D/S-100 is limited to the monitoring of 16 bits of binary angle input of the appropriate label (as shown in section (x) of this specification), within 1mS. With a maximum of +/-12 arc-minutes error of the LSB on the output.

The design of the D/S-100 is such as to cause minimal degradation of the input signal and to convert the data in the fastest and most accurate means possible.

(iii) INSTALLATION PROCEDURES

1. INTRODUCTION

This section contains information relative to the installation of the, D/S-100 XYZ Adapter, to assure satisfactory performance of the unit. (See Sections "iv" and "v" for detailed mechanical and wiring diagrams.)

2. UNPACKING AND INSPECTING EQUIPMENT

After unpacking the unit, make a visual inspection of the unit for evidence of damage incurred during shipment. If a claim for damage is to be made, save the shipping container to substantiate the claim.

3. PREINSTALLATION CHECK

Perform a continuity and power check on the wiring harness before connecting equipment.

4. POWER REQUIREMENTS

The D/S-100 operates from a standard 27.5 Volt DC aircraft power source, and 26 VAC 400 HZ reference. Provide circuit protection with an in line 1 AMP breaker on the 27.5 VDC.

5. POST INSTALLATION CHECK

There is no in-aircraft adjustment required for the D/S-100. All alignment and adjustment procedures are accomplished during bench maintenance.

6. PREFLIGHT CHECK

Following the manufactures check out procedures of the on board Direction Instrument, verify that the Direction indicators being driven by the D/S-100 are accurate.

(iv) INSTALLATION MECHANICAL DIAGRAMS

The D/S-100 is designed for flat mounting anywhere on board the aircraft, pressurized or unpressurized compartments. The unit has four (4) mounting holes for number (6) size screws. (NOTE: Screws and other miscellaneous mounting hardware are NOT included with the D/S-100.

Mechanical Drawing of D/S-100

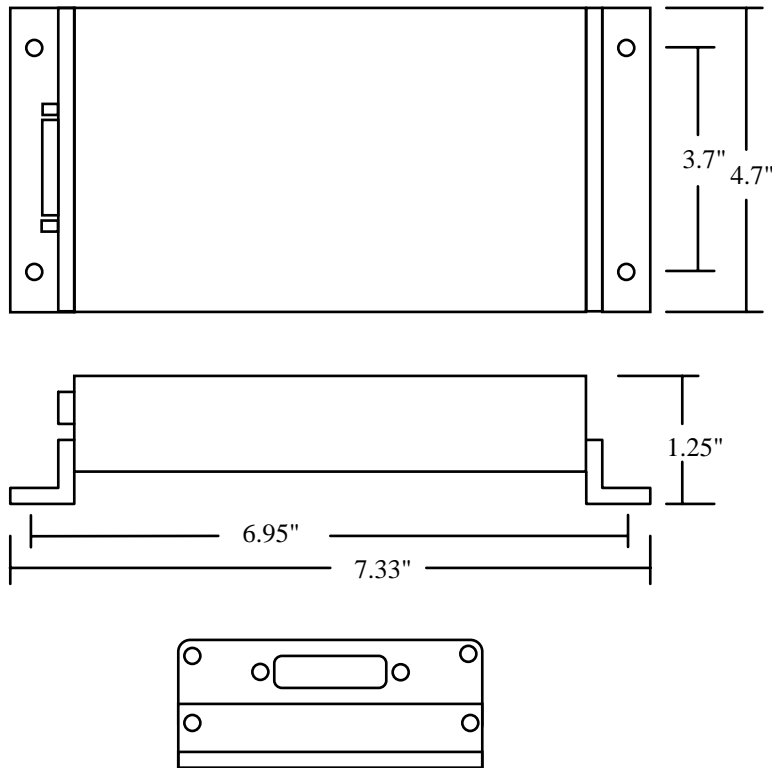

Unit Connector - DB25P with Screw Lock Retainers  
Mate - DB25S AMP P/N 205207-1 or Equivalent

(v) INSTALLATION WIRING DIAGRAMS

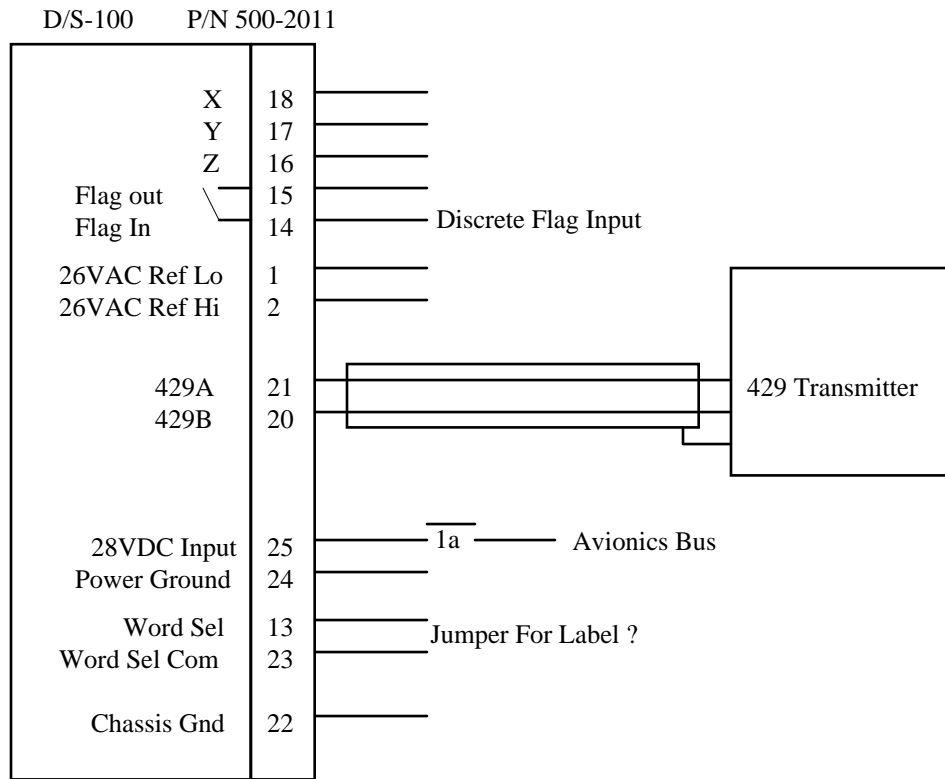

D/S-100, P/N 500-2011

NOTE (a) ARINC 407 INPUT DISPLAY

NOTE (b) HI or LOW SPEED ARINC GAMA 429 (P/N section (x) for label.)

NOTE (c) Flag In and Flag Out are contacts of a normally open relay that will be closed with a valid SSM and Synchro Excitation.

NOTE (d) PN 500-20(XX)-10 has two DS-100's in a single enclosure.

(vi) SPECIFICATIONS

SPECIFICATION	CHARACTERISTICS	
Compliance	TSO C5e/C6d	
DO160B	D1A1/B/A/NOM/X/X/X/X/X/A/A/A/A/A	
Physical Dimensions	Height	1.25"
	Length	7.35"
	Width	4.7"
	Weight	1.5lb
Temperature Range	Operational	-20 C to +70 C
	Storage	-55 C to +85 C
Altitude	50,000'	
Power Requirements	28 VDC @ .8 AMP Peak .3 AMP Normal 26 VAC @ .1 AMP Reference only	
Inputs	ARINC 429 Label 320 or 314 with 16 bit resolution Flag Discrete	
Outputs	ARINC 407 Synchro XYZ of 3 Passive Loads @ +/-12 arc-minutes Flag Discrete	
Flag output	Invalid	1 Meg Ohm From Flag input discrete
	Valid	1 Ohm From Flag input discrete
Limitations	Limited to the manufactures specifications of the digital input bus and to the specifications listed herein.	

(vii) EQUIPMENT SYSTEMS MAJOR COMPONENT

Equipment Supplied:

1 Model D/S-100 Digital to SYNCHRO Adapter  
Part Number 500-2011

Equipment Required But Not Supplied:

4 Standard Mounting Screws  
Connector Standard DB25S AMP P/N 205207-1 or equiv.  
Backshell with Latch

Interconnect Block Diagram

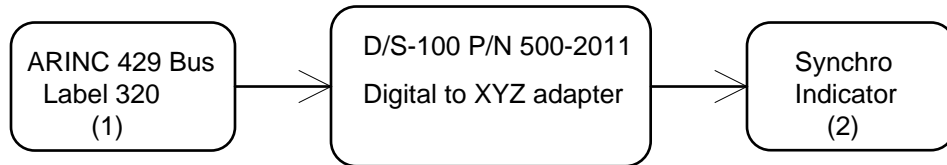

(1) Connect to Any ARINC GAMA 429 Output, Binary Angle, 429 BUS Interconnect Varies by Manufacturer.

(2) Connect to Any Standard, SYNCHRO Input.



(viii) ENVIRONMENTAL QUALIFICATION

Nomenclature: D/S-100 SYNCHRO Adapter  
 Part Number: 500-2011 TSO Number C5e/C6d

Test

Conditions	Section / Paragraph	Test Conducted
Temperature & Altitude	4.0	Equipment tested to Category: D2
Low Temperature	4.5.1	Equipment tested to Category: D2
High Temperature	4.5.2/3	Equipment tested to Category: D2
Altitude Tests	4.6.1	Equipment tested to Category: D2
Decompression Test	4.6.2	Equipment tested to Category: A1
Overcompression Test	4.6.3	Equipment tested to Category: A1
Temperature Variation	5.0	Equipment tested to Category: B
Humidity	6.0	Equipment tested to Category: A
Shock	7.0	Equipment Tested per DO-160B Paragraph 7
Operational	7.2	
Crash Safety	7.3	
Vibration	8.0	Equipment tested mounts to Categories N, O and P (DO-160B, Table 8-1)
Explosion Proofness	9.0	Equipment Identified as "X" no test required
Waterproofness	10.0	Equipment Identified as "X" no test required
Fluids Susceptibility	11.0	Equipment Identified as "X" no test required
Sand & Dust	12.0	Equipment Identified as "X" no test required
Fungus Resistance	13.0	Equipment Identified as "X" no test required
Salt Spray	14.0	Equipment Identified as "X" no test required
Magnetic Effect	15.0	Equipment tested as Class "A"
	16.0	Equipment tested as Class "A"
Voltage Spike	17.0	Equipment tested as Class "A"
Audio Frequency Conducted Susceptibility	18.0	Equipment tested as Class "A"
Induced Signal Susceptibility	19.0	Equipment tested as Class "A"
Radio Frequency Susceptibility	20.0	Equipment tested as Class "A"
Radio Frequency Emission	21.0	Equipment tested as Class "A"