

SKYLIGHT AVIONICS
MODEL IND-5000, P/N 50-5021-(XX)
INSTALLATION MANAUL

INSTALLATION MANUAL
Multi-Function Digital Bus Reader
Model IND-5000, P/N 50-5021-(XX)
TACAN, Distance & Bearing
June 1997

Skylight Avionics
38629 6th Str. East
Palmdale, CA. 93550
(661) 265-0497

SKYLIGHT AVIONICS
MODEL IND-5000, P/N 50-5021-(XX)
INSTALLATION MANUAL

INDEX

Section	Title	Page
i.	Operation Instructions	1
ii.	Equipment Limitations	1
iii.	Installation Procedures	2
iv.	Installation Specifications: Physical	3
v.	Installation Specifications: Electrical	4 & 5
vi.	Specifications	5
vii.	Major Components	6
viii.	Environmental Qualification Form	7 & 8

Illustrations

Illustration	Title	Page
iv-1	Mechanical Drawing of IND-5000	3
v-1	IND-5000 P/N 50-5020 Pinout	4
vi-1	Interconnect Block Diagram	7

i. Operating Instructions

1. General

The IND-5000, P/N 50-5020-(XX) operation is independent of the Aircraft Navigation system to which it is interfaced, operating instructions for that system will need to be followed. The indicator should become operational upon application of aircraft avionics power and provides the following information on a two line display.

BRG XXX	Bearing in Degrees.
DIS XXX.X	Distance to station in Kts.

2. Controls

The 50-5020-XX Indicator has one control on the front panel. The "DIM" control located on the lower right and adjusts the LED display brightness. (NOTE: The panel back lighting is controlled by the aircraft instrument panel dimming).

3. Flags and Warnings

The 50-5020-XX Indicator will detect the following failures from the serial data bus:

Condition	Display
No Serial Bus Input	IDLE
Invalid Bearing Valid Distance	BRG --- DIS 888.8
Valid Bearing Invalid Distance	BRG 888 DIS ---.-

ii. Equipment Limitations

The IND-5000 indicator is only a display of ARINC digital data received from other on-board flight or navigation system outputs. The update speed, accuracy, and data available for display is directly limited to the output of the system to which it is interfaced. In effect, it is a display component of that flight or navigation system and therefore subject to all inherent limitations of those systems.

The IND-5000 operates at 22 to 29.5 VDC power. It cannot be used for emergency 18 VDC operation.

iii. Installation Procedures

1. Introduction

This section contains information relative to the installation of the IND-5000 indicator to assure satisfactory performance of the unit. (See sections iv. and v. for detailed mechanical and wiring diagrams.)

2. Unpacking and Inspecting Equipment

After unpacking the IND-5000, make a visual inspection of the unit for evidence of damage incurred during shipment. If a claim for damage is to be made, save the shipping container to substantiate the claim.

3. Pre-Installation Check

The IND-5000 should be bench checked for proper system operation prior to being installed in the aircraft.

4. Power Requirements

The IND-5000 has been designed to accept from 22 to 29.5 VDC power with no special modification or wiring considerations. The IND-5000 operates from a standard +28 VDC aircraft power source. Circuit protection should be provided with an in-line 0.5 Amp breaker. Panel dimming for the unit can be either +5 or +28 VDC, depending on aircraft requirements.

5. Post-installation Check

Power: Upon application of the aircraft 28 VDC power verify the IND-5000 alphanumeric LED displays. (i.e. RECV IDLE) System Check: After the system to which the IND-5000 has been interfaced has been verified and is operating properly, verify that each data format function is operational. Verify numerical data to other system displays where applicable (i.e. CDU, EFIS, etc.).

iv. Installation Specifications: Physical

1. Mechanical

The IND-5000 is designed for rigid mounting in a aircraft instrument panel with a standard 1/2 3ATI cutout and mounting clamp.

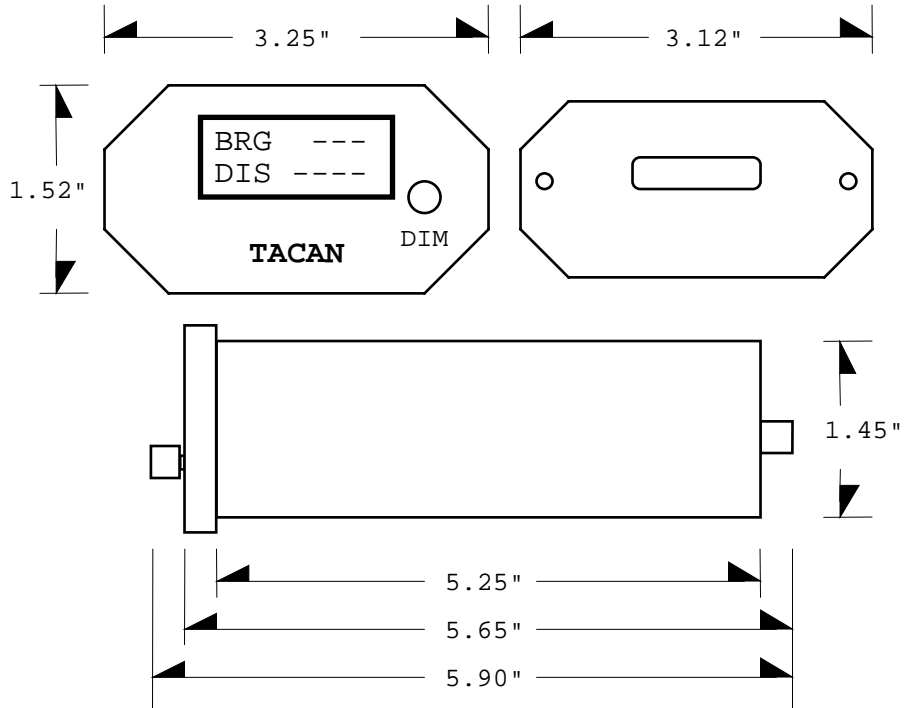

IND-5000, P/N 50-5021-(XX) Mechanical Drawing
(Illustration iv-1)

v. Installation Specifications: Electrical

1. Pinout Diagram

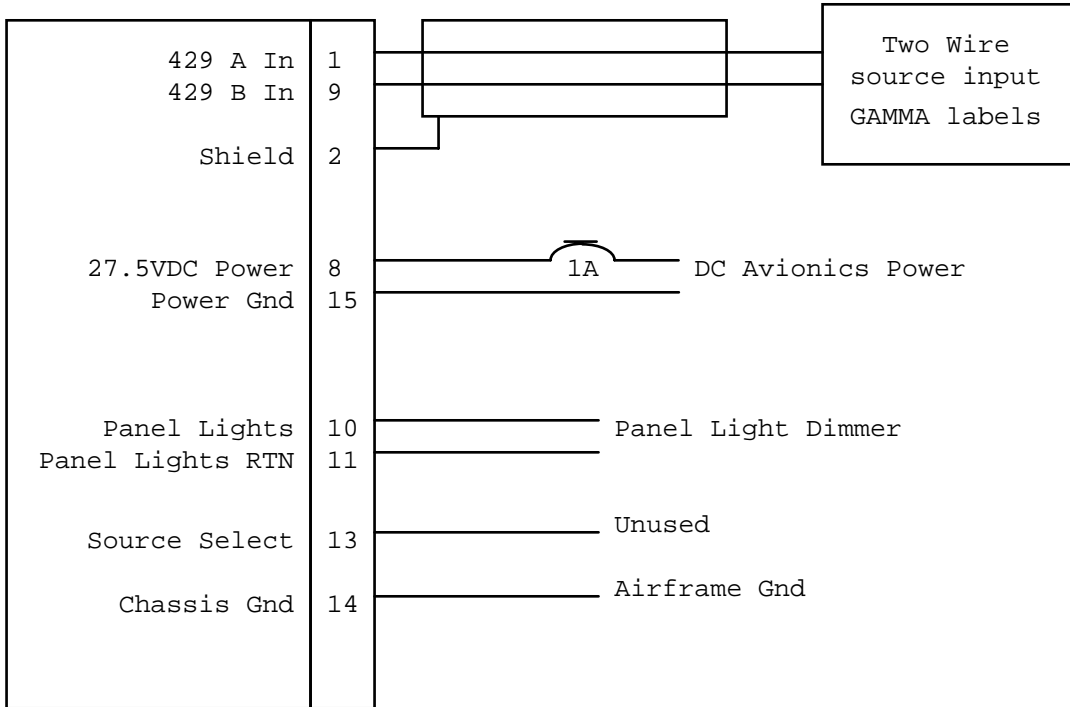

Connector: DA 15P (AMP P/N 745093-1)
 Mate: DA 15S (Standard 15 pin with male screw retainer)

IND-5000 P/N 50-5021-(XX) Pinout
 (illustration v-1)

v. Installation Specifications: Electrical (cont.)

Data Format, Bearing Label 222

Transmission rate: minimum of four times per second.

```

  Bit   3 | 332 | 222222222111 | 11111110 | 00000000
        2 | 109 | 876543210987 | 65432109 | 87654321
        --Z-----Z-----Z-----Z-----Z-----Z-----
        P | SSM | 2' Comp PI Rad | 00000000 | 01001001
  
```

Where: SSM is 110 = positive & 111 = negative, else invalid and P is odd parity.

Data Format, Distance Label 201

Transmission rate: minimum of four times per second.

```

  Bit   3 | 33 | 222 | 2222 | 2221 | 1111 | 111110 | 00000000
        2 | 10 | 987 | 6543 | 2109 | 8765 | 432109 | 87654321
        --Z-----Z-----Z-----Z-----Z-----Z-----Z-----Z-----Z-----Z-----
        P | SM | Hun | Tens | Units | Tenth | pad | 10000001
  
```

Where: SM is 01 = Test, 11 = Valid, else invalid and P is odd parity.

vi. General Specifications

Specification	Characteristics
Compliance	TSO C113 - SAE AS 8034, RTCA DO160B A1/B/A/KPS/XXXXXX/A/A/A/A/A/A
Display	5 X 7 Dot Matrix LED
Characters	English Font Alphanumeric
Character Size	0.20" X 0.112"
Contrast	Minimum 5 in 10K fc Direct Sunlight
Luminous Intensity	Minimum 2400 fc / Typical 3400 fc
Viewing Angle	Lateral 130o / Vertical 90o
Viewing Distance	10" to 100" (29" Nominal)
Physical Dimensions:	
Height	1.52"
Length	5.90"
Width	3.25"
Weight	18ozs.
Temperature Range	Operational: -20oC to +70oC
Altitude	Controlled environment equivalent to 15000 ft. nonpressurized.
Power Requirements	28VDC at 0.5 Amps Peak, 0.275 Amps nominal.
Digital Input	ARINC/ GAMMA 429 : Label 222(Bearing to Station) Label 201(Distance to Station)
Range	Bearing 0-360°, Distance 0-399.9kt
Accuracy	Bearing 0.35°, Distance 0.1 kt.

vii. Major Components

1. Equipment Supplied

Model IND-5000 P/N 50-5021-(XX)

Back Lighting Voltage	Faceplate Color	P/N
5V	Black	50-5021-01
5V	Gray	50-5021-11
28V	Black	50-5021-02
28V	Gray	50-5021-12

2. Equipment Required but not supplied

Standard 1/2 3ATI panel mounting clamp
 Connector kit : Standard DA 15S connector with screw retainers

3. Interconnection

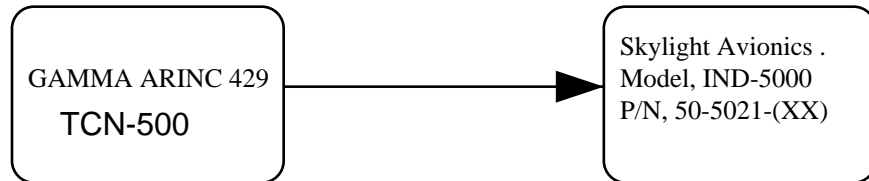

Interconnect Block Diagram
 (Illustration vii-1)

(a) Connect to any 429 general purpose bus which outputs correct GAMMA labels.
 Interconnect varies by manufacturer. (See Section v.)

viii.Environmental Qualification Form

1. Nomenclature: IND-5000 Multi-function Digital Bus Reader
 2. Part Number: 50-5021-(XX)
 3. TSO Number: C113
 4. Manufacture's Specification: None
 5. Manufacturer: Skylight Avionics Company
 38629 6th Street East
 Palmdale, CA. 93550, USA

6. TEST:

Conditions	Section/ Paragraph	Test Conducted
Temperature & Altitude	4.0	Equipment tested to Category: A1
Low Temperature	4.5.1	
High Temperature	4.5.2/3	
Altitude Tests	4.6.1	
Decompression Tests	4.6.2	
Overpressure Tests	4.6.3	
Temperature Variation	5.0	Category B
Humidity	6.0	Category A
Shock	7.0	Equipment tested per DO-160B Paragraph 7.1.1
Operational	7.2	
Crash Safety	7.3	
Vibration	8.0	Equipment tested without shock mounts to Categories K,P and S (DO-160B, Table 8-1)
Explosion	9.0	"X" No tests required
Waterproofness	10.0	"X" No tests required
Fluids Susceptibility	11.0	"X" No tests required
Sand & Dust	12.0	"X" No tests required

SKYLIGHT AVIONICS
MODEL IND-5000, P/N 50-5021-(XX)
INSTALLATION MANUAL

viii. Environmental Qualification Form (continued)

Conditions	Section/ Paragraph	Test Conducted
Fungus	13.0	"X" No tests required
Salt Spray	14.0	"X" No tests required
Magnetic Effect	15.0	Tested as Class "A"
Power Input	16.0	Category A
Voltage Spike	17.0	Category A
Audio Frequency Conducted Susceptibility	18.0	Category A
Induced Signal Susceptibility	19.0	Category A
Radio Frequency	20.0	Category A
Radio Frequency Emission	21.0	Category A

Remarks:

Tests 4.0, 5.0, 6.0, 7.0 and 8.0 were conducted at:
A-BEC Environmental Testing Laboratories.

Tests 15.0, 16.0, 17.0, 18.0, 19.0, 20.0 and 21.0 were conducted at:
McPete Systems Company, EMC Science Center.

Compliance to FAR part 25 demonstrated by component parts and material analysis.