

DESIGN SPECIFICATION
P/N 04120006,
NAV CONVERTER

Skylight Avionics
38629 6th Street East
Palmdale, California
(661) 265-0497

INDEX

Section	Title	Page
i.	OPERATING INSTRUCTIONS	1
ii.	EQUIPMENT LIMITATIONS	1
iii.	INSTALLATION PROCEDURES & LIMITATIONS	2
iv.	INSTALLATION MECHANICAL	3
v.	INSTALLATION ELECTRICAL	4
vi.	SPECIFICATIONS	5
vii.	MAJOR COMPONENTS	6
viii.	ENVIRONMENTAL REPORT	7

ILLUSTRATIONS

Illustration	Title	Page
(iv-1)	MECHANICAL DRAWING	3
(v-1)	INSTALLATION DRAWING	4
(vii-1)	INTERCONNECT BLOCK DIAGRAM	6

i. OPERATING INSTRUCTIONS

The adapter P/N 04120006, being a data format converter has no independent operating Instructions and is should be considered transparent to the VHF/NAV system. Being an integral part of the system, the operating instructions for that system will need to be followed.

ii. EQUIPMENT LIMITATIONS

The adapter, P/N 04120006, is limited to an adapting the VOR Bearing, the ILS vertical and horizontal deviation signals and associated discrete flag signals into an ARINC 429 output.

The adapter, P/N 04120006, as an integral component of the on board VHF/NAV the accuracy is directly limited to the output driving it. In effect, it is a component of that system and therefore subjected to all inherent limitations of that system.

A design assurance of "MINOR FAILURE" with AC 25.1309-1A dated 6/21/88 is used as a guide to design verification, documentation and manufacturing for Skylight P/N 04120006.

AC 25.1309-1A paragraph 6 section h. Failure Condition: The effects on the airplane and its occupants, both direct and consequential, caused or contributed to by one or more failures, considering relevant adverse operational or environmental conditions. Failure conditions may be classified according to their severity as follows:

Sub paragraph (1) Minor: Failure conditions that would not significantly reduce airplane safety, and which involve crew actions that are well within their capabilities. Minor failure conditions may include, for example, a slight reduction in safety margins or functional capabilities, a slight increase in crew workload, such a routine flight plan changes, or some inconvenience to occupants.

The adapter, P/N 04120006 is classified as "ON CONDITION" with no preventative maintenance required. No overhaul time limitations apply. No scheduled inspections to determine operational status are required. In the event of a failure the operator or cognizant maintenance facility shall remove the appliance and return it to Skylight Avionics for the repair or replacement.

iii. INSTALLATION PROCEDURES

1. INTRODUCTION

This section contains information relative to the installation of the, adapter, P/N 04120006, to assure satisfactory performance of the unit. (See Sections "6" and "7" for detailed mechanical and wiring diagrams.)

2. UNPACKING AND INSPECTING EQUIPMENT

After unpacking the unit, make a visual inspection of the unit for evidence of damage incurred during shipment. If a claim for damage is to be made, save the shipping container to substantiate the claim.

3. PREINSTALLATION CHECK

Perform a continuity and power check on the wiring harness before connecting equipment.

4. POWER REQUIREMENTS

The adapter, P/N 04120006 operates from a standard 27.5 Volt DC aircraft power source, Provide circuit protection with an in line 1 AMP breaker on the 27.5 VDC. Aircraft AC is used for reference only.

5. POST INSTALLATION CHECK

The VHF Navigation radio interfaced will need to be ramp tested with appropriate test equipment. Provide VOR and ILS signals to the antenna and verify proper meter movement and operation. Self test for the VHF navigation radio interfaced should be applied and indications compared to the primary indicators.

6. PREFLIGHT CHECK

Follow the manufactures check out procedures of the on board systems, to determine indications being driven by the adapter, P/N 04120006 are accurate. Self test for the VHF navigation radio interfaced should be applied and indications compared to the primary indicators.

iv. INSTALLATION MECHANICAL DIAGRAMS

The adapter, P/N 04120006, is designed for flat mounting anywhere inside the aircraft, pressurized or non-pressurized compartments. The unit has four (4) mounting holes for number (6) size screws. (NOTE: Screws and other miscellaneous hardware are NOT included with the adapter.)

MECHANICAL DRAWING

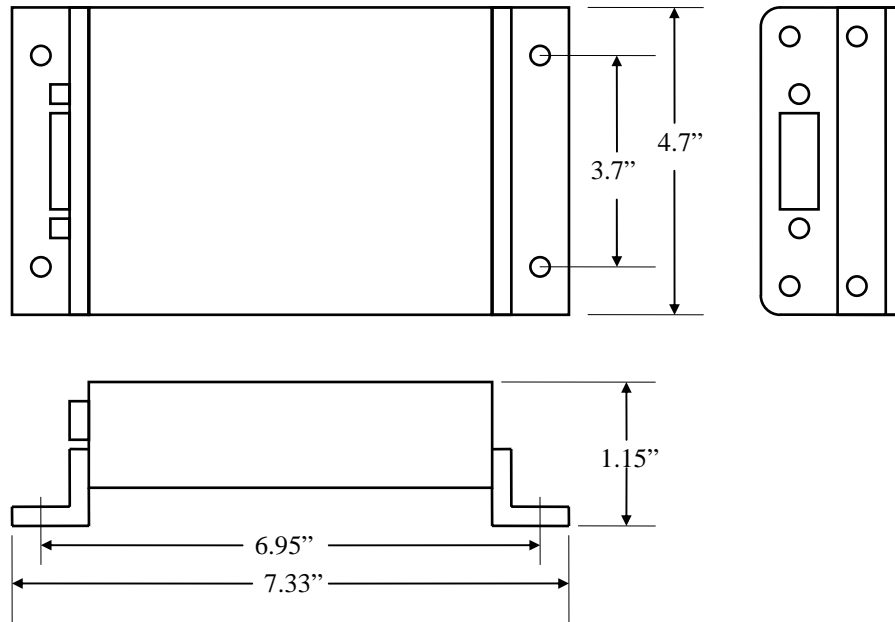

Unit Connector DB-25P, Mate - DB-25S

Mechanical Drawing P/N 04120006 (Illustration vi-1)

SKYLIGHT AVIONICS
 DESIGN SPECIFICATION
 NAV CONVERTER, P/N 04120006
 DOC. # 04120003, REV: 2, Date: 08/22/06

P/N 04120006

v. INSTALLATION ELECTRICAL

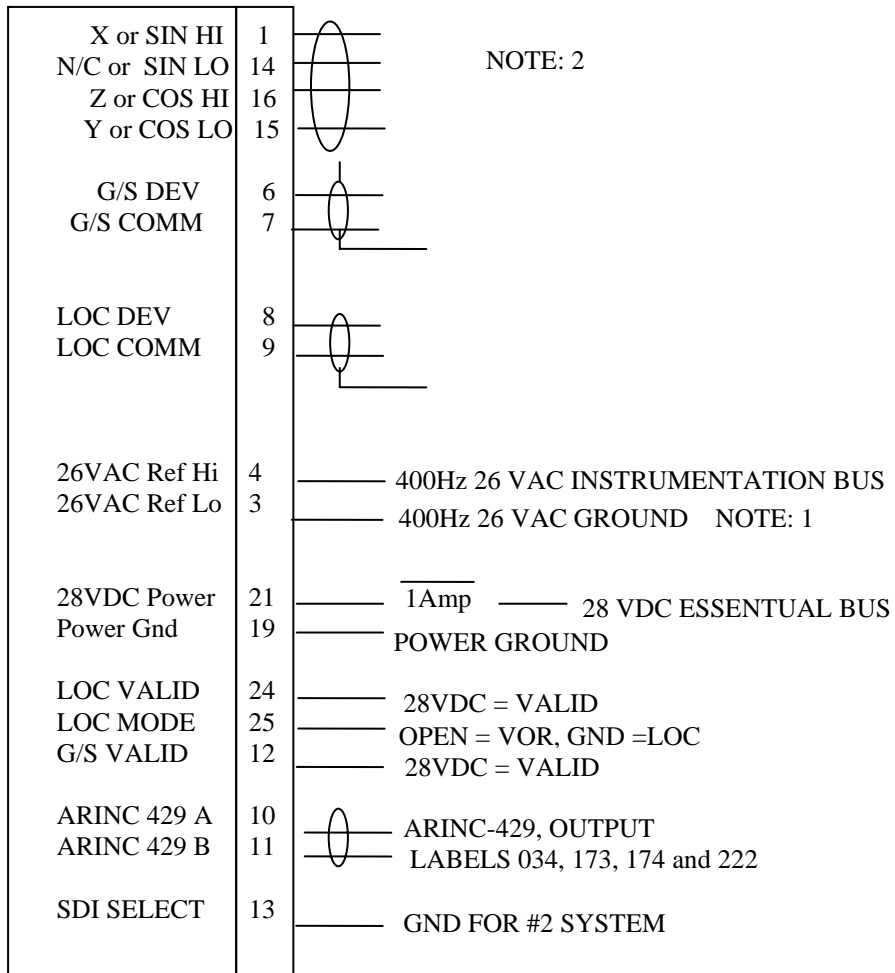

NOTE 1, The 26 VAC REF is isolated and may require inverting on some installations.
 NOTE 2, P/N 04120006 input XYZ Synchro, P/N 04120006-1 input SIN/COS.

P/N 04120006 Pinout (Illustration vii-1)

vi. SPECIFICATIONS

SPECIFICATION	CHARACTERISTICS
Physical Dimensions	Height 1.150" Length 7.350" Width 4.700" Weight 1.25lb
Temperature Range	Operational -40 C to +70 C Storage -55 C to +85 C
Altitude	50,000'
Power Requirements	28 VDC @ .8 AMP Peak .3 AMP Normal 26 VAC @ .1 AMP Reference only
ARINC- Inputs	ILS HORIZONTAL DEVIATION Impedance > 5,000 ohms Range +/- 0.2VDC MAX 25VDC G/S VERTICTAL DEVIATION Impedance > 5,000 ohms Range +/- 0.2VDC MAX 25VDC VOR BEARING ARINC 407, XYZ SYNCHRO or SINE COSINE 6.8 VAC MAX 26VAC Impedance 20,000 ohms Reference Voltage 26 VAC +/- 10%
P/N 04120006 P/N 04120006-1	
Discrete Inputs	LOC FLAG: 28VDC = Valid G/S FLAG: 28VDC = Valid LOC MODE: GND = LOC MODE SDI BITS: GND = SYSTEM # 2 Impedance 10,000 ohms,
Output	ARINC-429 Lo Speed @ 12.5 KHz Label: 034 caned word, Label: 173, +/- 0.005 ddm Label: 174, +/- 0.005 ddm Label: 222, +/- 0.5 degrees
Limitations	Limited to the manufactures specifications of the analog inputs and to the specifications listed herein.

vii. MAJOR COMPONENT

Equipment Supplied:

1ea VHF/NAV ANALOG TO ARINC 429, Part Number 04120006

Equipment Required But Not Supplied:

4ea. # 6 Mounting Screws

Connector: Standard DB25S, with Retention Screws.

Wiring Harness Interconnect cable

Interconnect Block Diagram

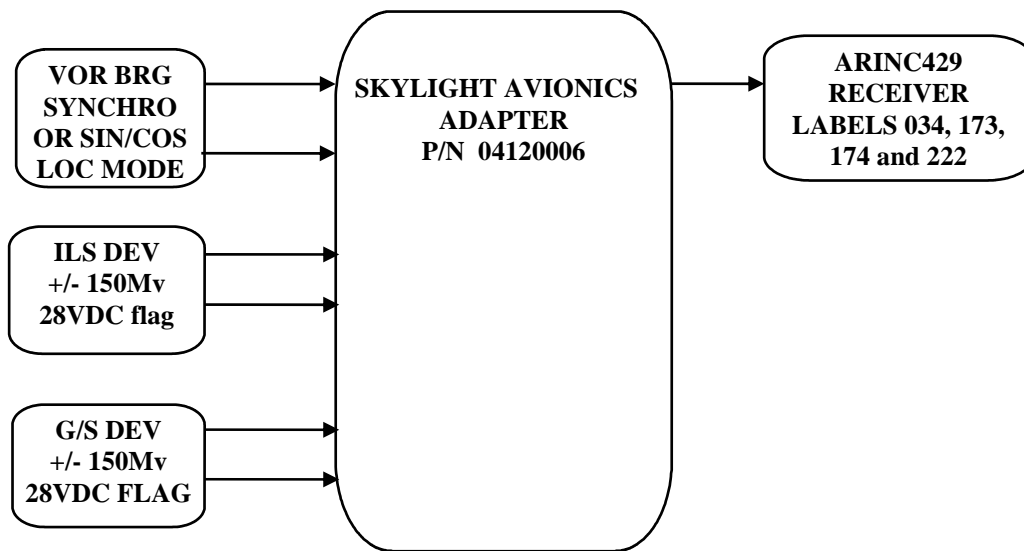

(Illustration vii-1)

SKYLIGHT AVIONICS
 DESIGN SPECIFICATION
 NAV CONVERTER, P/N 04120006
 DOC. # 04120003, REV: 2, Date: 08/22/06

viii. ENVIRONMENTAL REPORT

NOMENCLATURE: NAV CONVERTER
 MODEL / PART NO: P/N 04120006
 MANUFACTURE'S SPECIFICATION: NONE
 MANUFACTURE: SKYLIGHT AVIONICS
 ADDRESS: 38629 6th STREET EAST, PALMDALE, CA. 93550-3717

RTCA/DO-160E, Dated, December 9, 2004

DATE TESTED: (TBD)

Conditions	Section	Description of Conducted Tests
Temperature and Altitude	4.0	Equipment tested to Category D2 Auxiliary air cooling not required.
Temperature Variation	5.0	Equipment tested to Category B
Humidity	6.0	Equipment tested to Category A
Operational Shock and Crash Safety	7.0	Equipment tested to Category B operational and crash safety
Vibration	8.0	Equipment tested Category S, Zone 1, Curves [CLM]
Explosion	9.0	Category X no test required
Waterproofness	10.0	Category X no test required
Fluids Susceptibility	11.0	Category X no test required
Sand and Dust	12.0	Category X no test required
Fungus	13.0	Category X no test required
Salt Spray	14.0	Category X no test required
Magnetic Effect	15.0	Equipment tested to Category Z
Power Input	16.0	Equipment tested to Category Z and Emergency
Voltage Spike	17.0	Equipment tested to Category A
Audio Frequency Susceptibility	18.0	Equipment tested to Category Z
Induced Signal Susceptibility	19.0	Equipment tested to Category AC
Radio Frequency Susceptibility	20.0	Equipment tested to Category TT
Radio Frequency Emission	21.0	Equipment tested to Category M
Lighting Induced Transient Susceptibility	22.0	Equipment tested to Category XE3X Single Stroke
Lighting Direct Effects	23.0	Category X no test required
Icing	24.0	Category X no test required
Electrostatic Discharge	25.0	Equipment tested to Category A
Fire, Flammability	26.0	Category X no test required

Remarks:
 Compliance to FAR Part 25 demonstrated by component parts and material analysis.