

DESIGN SPECIFICATION
AIRSPEED DISCRETE OUTPUT UNIT
P/N 01060001

Skylight Avionics
38629 6th Street East
Palmdale, California
(661) 265-0497

INDEX

Section	Title	Page
i.	OPERATING INSTRUCTIONS	1
ii.	EQUIPMENT LIMITATIONS	1
iii.	INSTALLATION PROCEDURES & LIMITATIONS	2
iv.	INSTALLATION MECHANICAL	3
v.	INSTALLATION ELECTRICAL	4
vi.	SPECIFICATIONS	5
vii.	MAJOR COMPONENTS	6
viii	ENVIRONMENTAL QUALIFICATION FORM	7

ILLUSTRATIONS

	Title	
(vii-1)	MECHANICAL DRAWING	3
(iv-1)	INSTALLATION DRAWING	4
(v-1)	INTERCONNECT BLOCK DIAGRAM	6

SKYLIGHT AVIONICS
AIRSPEED DISCRETE OUTPUT UNIT, P/N: 01060001
DOC # 01060014, REV: 1, Date: 10/11/01

i. OPERATING INSTRUCTIONS

The Adapter P/N: 01060001, by design has no independent operating instructions. Being a digital to discrete adapter, operating instructions for the systems interfaced will need to be followed.

ii. EQUIPMENT LIMITATIONS

The Adapter P/N: 01060001, is limited to the conversion of the ARINC-429 Input (Label 260), into a maximum of 9 discrete relay outputs. Providing both the ARM and Contact of the relay to allow the installing agency maximum versatility.

The Adapter P/N: 01060001, is limited by the on board systems providing the digital input and the design requirements of the interconnecting systems. As such the check out procedures of the interfacing systems will need to be followed for system verification.

The design of the Adapter P/N: 01060001, is such as to cause minimal degradation of the input signal and to convert the data in the fastest and most accurate means possible.

iii. INSTALLATION PROCEDURES

1. INTRODUCTION

This section contains information relative to the installation of the Adapter to assure satisfactory performance of the unit. (See Sections "iv" and "v" for detailed mechanical and wiring diagrams.)

2. UNPACKING AND INSPECTING EQUIPMENT

After unpacking the unit, make a visual inspection of the unit for evidence of damage incurred during shipment. If claim for damage is to be made, save the shipping container to substantiate the claim.

3. PREINSTALLATION CHECK

Perform a continuity and power check on the wiring harness before connecting equipment.

4. POWER REQUIREMENTS

The Adapter operates from a standard 27.5 VDC aircraft power source, Provide circuit protection with an in line 1 AMP breaker on the 27.5 VDC

5. POST INSTALLATION CHECK

There is no in-aircraft adjustment required for the Adapter. All alignment and adjustment procedures are accomplished during bench maintenance.

6. PREFLIGHT CHECK

Follow the manufactures check out procedures of the on board systems, to determine indications being driven by the Adapter are accurate.

iv. INSTALLATION MECHANICAL DIAGRAMS

The Adapter is designed for flat mounting anywhere on board the aircraft, pressurized or unpressurized compartments. The unit has four (4) mounting holes for number (6) size screws. (NOTE: Screws and other miscellaneous mounting hardware are NOT included.)

MECHANICAL DRAWING

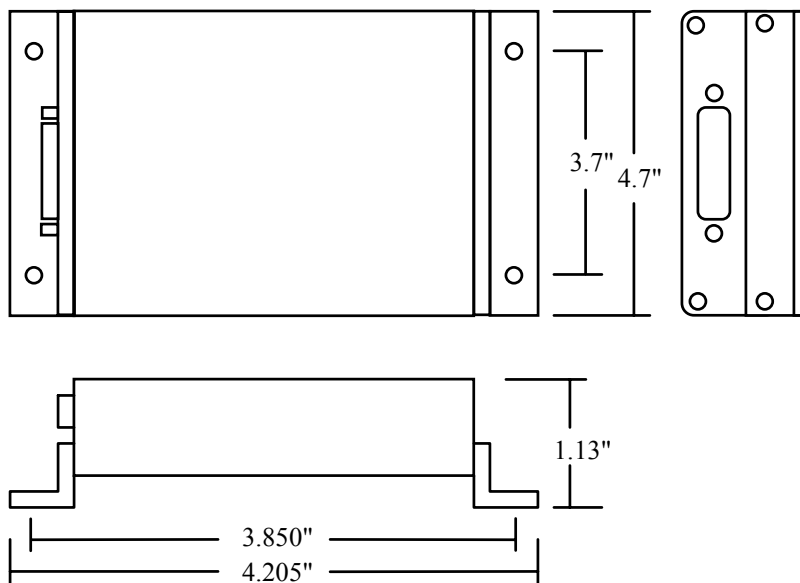

Unit Connector - DB-25P, Mate - DB-25S

Mechanical Drawing of Adapter, P/N: 01060001
(Illustration iv-1)

SKYLIGHT AVIONICS
 AIRSPEED DISCRETE OUTPUT UNIT, P/N: 01060001
 DOC # 01060014, REV: 1, Date: 10/11/01

v. INSTALLATION ELECTRICAL

AIRSPEED DISCRETE
 P/N 01060001

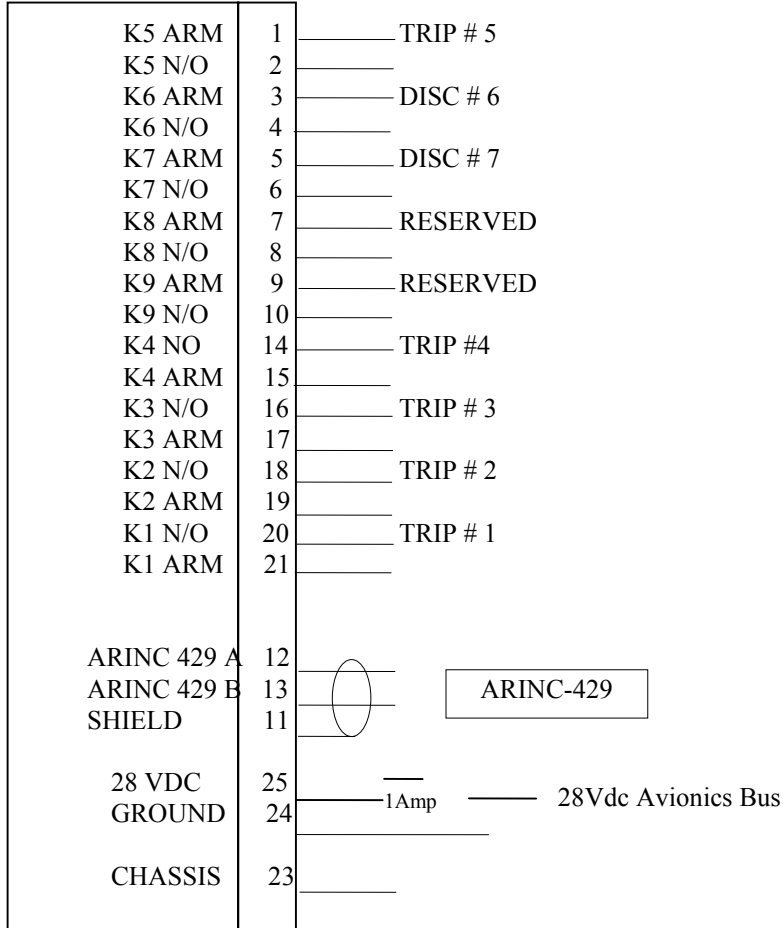

ADAPTER, P/N: 01060001, Pin out

(Illustration v-1)

SKYLIGHT AVIONICS
 AIRSPEED DISCRETE OUTPUT UNIT, P/N: 01060001
 DOC # 01060014, REV: 1, Date: 10/11/01

vi. SPECIFICATIONS

SPECIFICATION CHARACTERISTICS

Physical Dimensions:

Height	1.13"
Length	4.205"
Width	4.70"
Weight	.75 lb.

Temperature Range

Operation	-20 C to +70 C
Storage	-55 C to +85 C

Altitude 55000 FT

Power Requirements 28 VDC @ .3A Nominal

Digital Inputs ARINC 429, High Speed (100KHZ.)
 Label 260 @ 5HZ, Bit Definition

1-8	Octal Label				
9-19	Pad low				
20	(Reserved)			1=Active	
21	(Reserved)			1=Active	
22	Discrete Output #7			1=Active	
23	Discrete Output #6			1=Active	
24	Airspeed Trip #5			1=Active	
25	Airspeed Trip #4			1=Active	
26	Airspeed Trip #3			1=Active	
27	Airspeed Trip #2			1=Active	
28	Airspeed Trip #1			1=Active	
29	Pad				
30	SSM	0 NORM	1 NCD	0 Test	1 Not
31	SSM	0	0	1	1 Used
32	Parity (odd)				

Outputs 9 Discrete Relay Outputs
 Bit 20 = Reserved
 Bit 21 = Reserved
 Bit 22 = Discrete Output # 7
 Bit 23 = Discrete Output # 6
 Bit 24 = Airspeed Trip # 5
 Bit 25 = Airspeed Trip # 4
 Bit 26 = Airspeed Trip # 3
 Bit 27 = Airspeed Trip # 2
 Bit 28 = Airspeed Trip # 1

Failures Invalid SSM = Instant release of all relays.
 Loss of Bus = Release of all relays within 1.5 Seconds.

Limitations: Limited to the Manufactures specifications of the units making up the interface.

SKYLIGHT AVIONICS
AIRSPEED DISCRETE OUTPUT UNIT, P/N: 01060001
DOC # 01060014, REV: 1, Date: 10/11/01

vii. MAJOR COMPONENT

Equipment Supplied

1. Adapter P/N: 01060001

Equipment Required But Not Supplied

4 Standard Mounting Screws	Determined By Install
1 Connector Standard DA 15S	AMP P/N 205205-1 or equivalent
1 Back Shell with latch	

Interconnect Block Diagram

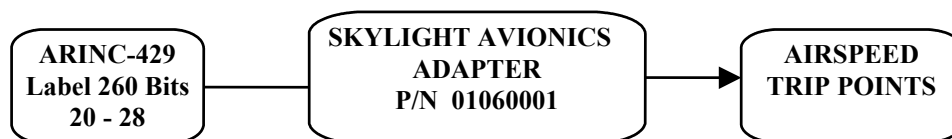

(Illustration vii-1)

SKYLIGHT AVIONICS
 AIRSPEED DISCRETE OUTPUT UNIT, P/N: 01060001
 DOC # 01060014, REV: 1, Date: 10/11/01

viii. ENVIRONMENTAL QUALIFICATION FORM

NOMENCLATURE: AIRSPEED DISCRETE OUTPUT UNIT
 MODEL / PART NO: P/N 01060001
 MANUFACTURE'S SPECIFICATION: NONE
 MANUFACTURE: SKYLIGHT AVIONICS
 ADDRESS: 38629 6th STREET EAST, PALMDALE, CA. 93550-3717

RTCA/DO-160D, Dated, July 29, 1997

DATE TESTED:

Conditions	Section	Description of Conducted Tests
Temperature and Altitude	4.0	Equipment tested to Category F1 Auxiliary air cooling not required.
Temperature Variation	5.0	Equipment tested to Category B
Humidity	6.0	Equipment tested to Category A
Operational Shock and Crash Safety	7.0	Equipment tested to Category B operational and crash safety
Vibration	8.0	Equipment tested Category T, Zone 2, Curves [BB1R]
Explosion	9.0	Category X no test required
Waterproofness	10.0	Category X no test required
Fluids Susceptibility	11.0	Category X no test required
Sand and Dust	12.0	Category X no test required
Fungus	13.0	Category X no test required
Salt Spray	14.0	Category X no test required
Magnetic Effect	15.0	Equipment tested to Category A
Power Input	16.0	Equipment tested to Category A
Voltage Spike	17.0	Equipment tested to Category A
Audio Frequency Susceptibility	18.0	Equipment tested to Category A
Induced Signal Susceptibility	19.0	Equipment tested to Category Z
Radio Frequency Susceptibility	20.0	Equipment tested to Category WWR
Radio Frequency Emission	21.0	Equipment tested to Category L
Lighting Induced Transient Susceptibility	22.0	Equipment tested to Category XXE4 Cable Bundle Tests
Lighting Direct Effects	23.0	Category X no test required
Icing	24.0	Category X no test required
Electrostatic Discharge	25.0	Equipment tested to Category A

Remarks:

Compliance to FAR Part 25 demonstrated by component parts and material analysis.

Environmental tests were conducted at:

ENVIRONMENT ASSOCIATES, INC
 9604 VARIEL AVE.
 CHATSWORTH, CA. 91311
 (Sections 4 - 8) Report # (TBD)

NEMKO EESI
 9604 VARIEL AVE.
 CHATSWORTH, CA. 91311
 (Sections 15 - 25) Report # (TBD)