

DESIGN SPECIFICATION  
AIR DATA ADAPTER UNIT  
P/N 01060002

SKYLIGHT AVIONICS  
38629 6th Street East  
Palmdale, California  
(661) 265-0497

INDEX

Section	Title	Page
i.	OPERATING INSTRUCTIONS	1
ii.	EQUIPMENT LIMITATIONS	1
iii.	INSTALLATION PROCEDURES & LIMITATIONS	2
iv.	INSTALLATION MECHANICAL	3
v.	INSTALLATION ELECTRICAL	4
vi.	SPECIFICATIONS	5
vii.	MAJOR COMPONENTS	6
viii.	ENVIRONMENTAL QUALIFICATION FORM	7
ix.	BENCH CHECK AND ALIGNMENT	8 & 9

ILLUSTRATIONS

	Title	
(iv-1)	MECHANICAL DRAWING	3
(v-1)	INSTALLATION DRAWING	4
(vii-1)	INTERCONNECT BLOCK DIAGRAM	6

SKYLIGHT AVIONICS  
Air Data Adapter Unit, P/N 01060002  
DOC. # 01060011, REV: 1, Date: 10/11/01

i. OPERATING INSTRUCTIONS

The Adapter P/N 01060002, by design has no independent operating instructions for normal operation. There is a ground to test input that may be incorporated. Being a digital to analog adapter, operating instructions for the systems interfaced will need to be followed.

ii. EQUIPMENT LIMITATIONS

The Adapter P/N 01060002 is limited to being a format adapter of the ARINC-429 input into DC analog. As such is limited by the on board systems providing the digital input and the design requirements of the system it is driving.

The Adapter is designed to cause minimal degradation of the input signal and to convert the data in the fastest and most accurate means possible.

### iii. INSTALLATION PROCEDURES

#### 1. INTRODUCTION

This section contains information relative to the installation of the Adapter to assure satisfactory performance of the unit. (See Sections "6" and "7" for detailed mechanical and wiring diagrams.)

#### 2. UNPACKING AND INSPECTING EQUIPMENT

After unpacking the unit, make a visual inspection of the unit for evidence of damage incurred during shipment. If claim for damage is to be made, save the shipping container, to substantiate the claim.

#### 3. PREINSTALLATION CHECK

Perform a continuity and power check on the wiring harness before connecting equipment.

#### 4. POWER REQUIREMENTS

The Adapter operates from a 27.5 VDC aircraft power source, Provide circuit protection with an in line 1 AMP breaker on the 27.5 VDC

#### 5. POST INSTALLATION CHECK

There is no in-aircraft adjustment required for the Adapter. All alignment and adjustment procedures are accomplished during bench maintenance.

#### 6. PREFLIGHT CHECK

Follow the manufactures check out procedures of the on board systems, to determine indications being driven by the Adapter are accurate.

iv. INSTALLATION MECHANICAL DIAGRAMS

The Adapter is designed for flat mounting anywhere on board the aircraft pressurized or unpressurized compartments. The unit has four (4) mounting holes for number (6) size screws. (NOTE: Screws and other miscellaneous mounting hardware are NOT included.)

MECHANICAL DRAWING

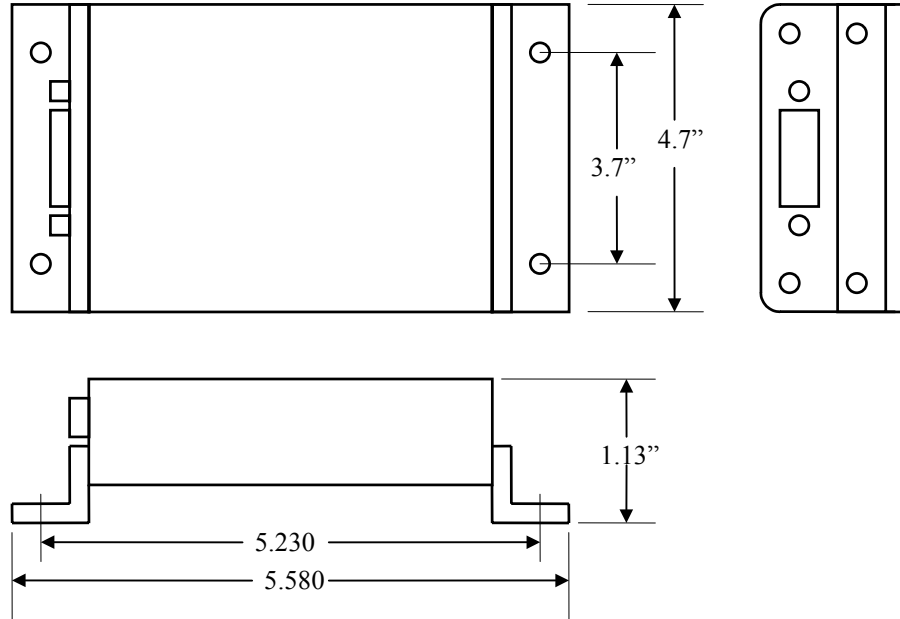

Unit Connector - DA15P, Mate - DA15S

Mechanical Drawing of Adapter, P/N 01060002  
(Illustration iv-1)

v. INSTALLATION ELECTRICAL

ADAPTER P/N 01060002

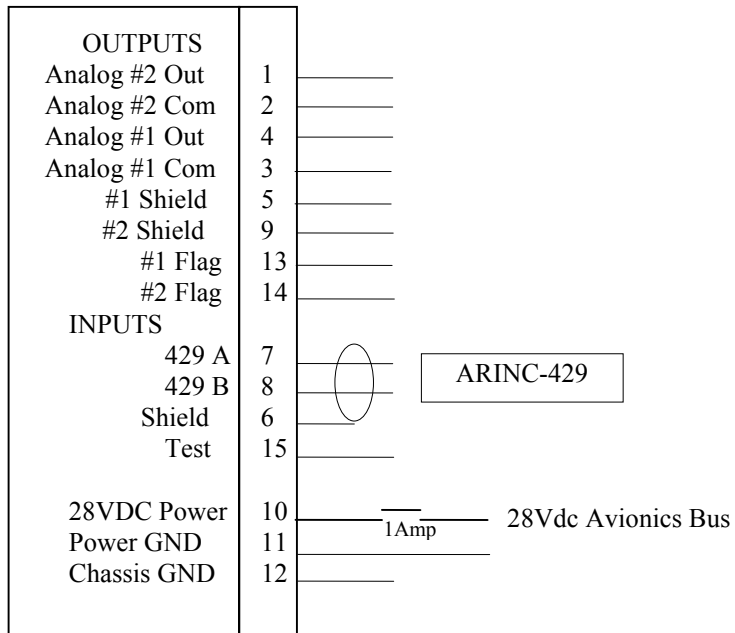

ADAPTER, P/N 01060002, Pin out  
 (Fig. v-1)



SKYLIGHT AVIONICS

Air Data Adapter Unit, P/N 01060002

DOC. # 01060011, REV: 1, Date: 10/11/01

vii. MAJOR COMPONENT

Equipment Supplied

- 1. Adapter P/N 01060002

Equipment Required But Not Supplied

- 4 Standard Mounting Screws      Determined By Install
- 1 Connector Standard DA 15S      AMP P/N 205205-1 or equivalent
- 1 Back Shell with latch

Interconnect Block Diagram



(Illustration vii-1)



SKYLIGHT AVIONICS  
 Air Data Adapter Unit, P/N 01060002  
 DOC. # 01060011, REV: 1, Date: 10/11/01

viii. ENVIRONMENTAL QUALIFICATION FORM

NOMENCLATURE: AIR DATA ADAPTER UNIT  
 MODEL / PART NO: P/N 01060002  
 MANUFACTURE'S SPECIFICATION; NONE  
 MANUFACTURE: SKYLIGHT AVIONICS  
 ADDRESS: 38629 6<sup>th</sup> STREET EAST, PALMDALE, CA. 93550-3717

RTCA/DO-160D, Dated, July 29, 1997

DATE TESTED:

Conditions	Section	Description of Conducted Tests
Temperature and Altitude	4.0	Equipment tested to Category F1 Auxiliary air cooling not required.
Temperature Variation	5.0	Equipment tested to Category B
Humidity	6.0	Equipment tested to Category A
Operational Shock and Crash Safety	7.0	Equipment tested to Category B operational and crash safety
Vibration	8.0	Equipment tested Category T, Zone 2, Curves [BB1R]
Explosion	9.0	Category X no test required
Waterproofness	10.0	Category X no test required
Fluids Susceptibility	11.0	Category X no test required
Sand and Dust	12.0	Category X no test required
Fungus	13.0	Category X no test required
Salt Spray	14.0	Category X no test required
Magnetic Effect	15.0	Equipment tested to Category A
Power Input	16.0	Equipment tested to Category A
Voltage Spike	17.0	Equipment tested to Category A
Audio Frequency Susceptibility	18.0	Equipment tested to Category A
Induced Signal Susceptibility	19.0	Equipment tested to Category Z
Radio Frequency Susceptibility	20.0	Equipment tested to Category WWR
Radio Frequency Emission	21.0	Equipment tested to Category L
Lighting Induced Transient Susceptibility	22.0	Equipment tested to Category XXE4 Cable Bundle Tests
Lighting Direct Effects	23.0	Category X no test required
Icing	24.0	Category X no test required
Electrostatic Discharge	25.0	Equipment tested to Category A

Remarks:

Compliance to FAR Part 25 demonstrated by component parts and material analysis.

Environmental tests were conducted at:

ENVIRONMENT ASSOCIATES, INC  
 9604 VARIEL AVE.  
 CHATSWORTH, CA. 91311  
 (Sections 4 - 8) Report # (TBD)

NEMKO EESI  
 9604 VARIEL AVE.  
 CHATSWORTH, CA. 91311  
 (Sections 15 - 25) Report # (TBD)

ix. BENCH CHECK AND ALIGNMENT

GENERAL

This section provides all the instructions required for aligning and verification of the Air Data Adapter Unit, P/N 01060002. For terminology used for the operation of the ARINC 429 Transmitter, reference the GP-429 Receiver/Transmitter used by Skylight Avionics.

Equipment Required for Bench Check and Alignment

28 Volt Power Supply  
ARINC 429 Transmitter  
DVM 4 1/2 Digit, (Calibrated)  
Interconnect Cable (Fabricate locally)

Bench Check & Alignment

1. Connect unit to the test rig and apply power, allow 5 to 10 minutes warm up before Aligning.
2. Initiate the GP-429 and Restore the 01060002.CNF. Verify the following signals.

GP-429, Transmitter

070/0 1(200 msec) Airspeed = 0.00 Knots      SSM = 3  
071/0 1(200 msec) Airspeed = 0.00 Knots      SSM = 3

- a. Pin 13 to GND = 27.50 VDC
- b. Pin 14 to GND = 27.50 VDC
- c. Pin 1 to Pin 2 = 0.000 VDC +/- 0.002
- d. Pin 3 to Pin 4 = 0.000 VDC +/- 0.006

3. Edit the GP-429 Transmitter as follows, verify results.

GP-429, Transmitter

070/0 1(200 msec) Airspeed = 0.00 Knots      SSM = 0  
071/0 1(200 msec) Airspeed = 0.00 Knots      SSM = 0

- a. Pin 13 to GND = 0.0 VDC
- b. Pin 14 to GND = 0.0 VDC
- c. Pin 1 to Pin 2 = 0.000 VDC +/- 0.002
- d. Pin 3 to Pin 4 = 0.000 VDC +/- 0.006

4. Edit the GP-429 Transmitter as follows, verify results.

GP-429, Transmitter

070/0 1(200 msec) Airspeed = 512.00 Knots      SSM = 2  
071/0 1(200 msec) Airspeed = 512.00 Knots      SSM = 2

- a. Pin 13 to GND = 27.5 VDC
- b. Pin 14 to GND = 27.5 VDC
- c. Pin 1 to Pin 2 = 9.997 VDC +/- 0.002 ( Adjust R6 as required.)

SKYLIGHT AVIONICS

Air Data Adapter Unit, P/N 01060002

DOC. # 01060011, REV: 1, Date: 10/11/01

d. Pin 3 to Pin 4 = 25.993 VDC +/- 0.006 (Adjust R15 as required.)

ix. BENCH CHECK AND ALIGNMENT (cont.)

5. Edit the GP-429 Transmitter as follows, verify results.

GP-429, Transmitter

070/0 1(200 msec) Airspeed = 512.00 Knots      SSM = 1

071/0 1(200 msec) Airspeed = 512.00 Knots      SSM = 1

- a. Pin 13 to GND = 0.0 VDC
- b. Pin 14 to GND = 0.0 VDC
- c. Pin 1 to Pin 2 = 0.000 VDC +/- 0.002
- d. Pin 3 to Pin 4 = 0.000 VDC +/- 0.006

6. Edit the GP-429 Transmitter as follows, verify results.

GP-429, Transmitter

070/0 1(200 msec) Airspeed = 256.00 Knots      SSM = 3

071/0 1(200 msec) Airspeed = 256.00 Knots      SSM = 3

- a. Pin 13 to GND = 27.5 VDC
- b. Pin 14 to GND = 27.5 VDC
- c. Pin 1 to Pin 2 = 5.000 VDC +/- 0.002
- d. Pin 3 to Pin 4 = 13.000 VDC +/- 0.006

7. Edit the GP-429 Transmitter as follows, verify results.

GP-429, Transmitter

070/0 1(200 msec) Airspeed = 0.00 Knots      SSM = 3      Rate 10

071/0 1(200 msec) Airspeed = .000 Knots      SSM = 3      Rate 10

- a. Pin 13 to GND = 27.5 VDC
- b. Pin 14 to GND = 27.5 VDC
- c. Pin 1 to Pin 2 = Voltage changes in 0.004 VDC steps.
- d. Pin 3 to Pin 4 = Voltage changes in 0.012 VDC steps.

8. Push the Self Test Switch, verify results.

- a. Pin 13 to GND = 27.5 VDC
- b. Pin 14 to GND = 27.5 VDC
- c. Pin 1 to Pin 2 = 9.300 VDC +/- 0.012.
- d. Pin 3 to Pin 4 = 15.500 VDC +/- 0.025.

This completes the test, if problems were detected return unit for repair.

SKYLIGHT AVIONICS  
Air Data Adapter Unit, P/N 01060002  
DOC. # 01060011, REV: 1, Date: 10/11/01